



EINBAURAHMEN

INSTALLATION SUBFRAMES FOR EXTERNAL WEATHER LOUVRES

FOR THE FAST AND SIMPLE INSTALLATION OF EXTERNAL WEATHER LOUVRES

Installation subframes for the fast and precise installation of external weather louvres. Installation subframes with fixing tabs are mortared into the wall opening, then the external weather louvres are fastened to the subframes.

- Angle sections made of galvanised steel or stainless steel
- Fixing tabs with integral nuts to screw on the external weather louvre
- Subframe for external weather louvres of Type WGK, shipped as individual frame sections with tongue joints

Optional equipment and accessories

- Multi-section constructions, with width or height subdivided

Application



Application

- For the installation of louvres in walls
- Simplified installation
- The installation subframe allows for the fast, simple and precise installation of louvres

Description



Parts and characteristics

- Installation subframe consisting of angle sections
- Hexagon head screws
- Washers
- Fixing tabs with integral nuts

Materials and surfaces

WG, WG-AL, WG-JZ, WG-AL-JZ, WG-KUL, WG-AL-KUL

- Installation subframe made of galvanised steel (angle section $35 \times 35 \times 3$ mm)
- Welded fixing tabs with integral nuts, screws and washers made of galvanised steel

WG-A2

- Installation subframe made of stainless steel, material no. 1.4301
- Welded fixing tabs with integral nuts, screws and washers made of stainless steel, material no. 1.4301

WGK

- Installation subframes, made of formed galvanised sheet steel, with fixing tabs
- Screws and washers made of galvanised steel

TECHNICAL INFORMATION

Function



Installation subframe, made of steel, for external weather louvres

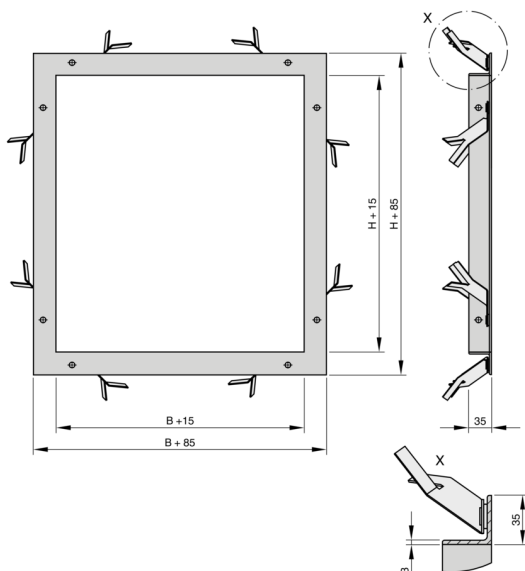

Variants, Dimensions and weight



Installation subframe for external weather louvres

Description	External weather louvre (Type)
Galvanised steel	WG, WG-AL, WG-JZ, WG-AL-JZ, WG-KUL, WG-AL-KUL
Galvanised steel, width subdivided	WG, WG-AL
Galvanised steel, height subdivided	WG, WG-AL
Galvanised steel, horizontal runs	WG-B-AL
Stainless steel	WG-A2
Stainless steel, width subdivided	WG-A2
Stainless steel, height subdivided	WG-A2
Galvanised steel	WGK

Materials

Part	Type or variant of external weather louvre	Material	Notes
Installation subframe	WG, WG-AL, WG-JZ, WG-AL-JZ, WG-KUL, WG-AL-KUL	Galvanised steel	Angle section 35 × 35 × 3 mm
	WG-A2	Stainless steel, material no. 1.4301	
Installation subframe	WGK	Galvanised steel	
Fixing tabs, screws, nuts and washers	WG, WG-AL, WG-JZ, WG-AL-JZ, WG-KUL, WG-AL-KUL	Galvanised steel	Welded fixing tabs
	WG-A2	Stainless steel, material no. 1.4301	Welded fixing tabs
Screws and washers	WGK	Galvanised steel	

Installation subframe, made of steel, for external weather louvres

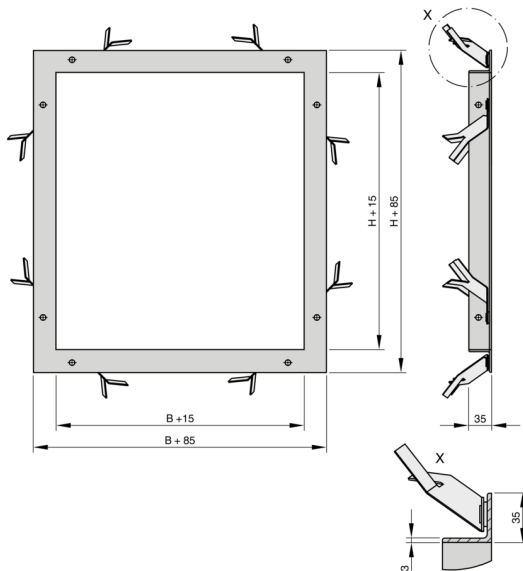

Installation details



Installation and commissioning

Before mortaring in the installation subframe

- Bend and spread the fixing tabs

After mortaring in the installation subframe

- Align the louvre with the installation subframe and fasten it

Installation dimensions - WG, WG-A2

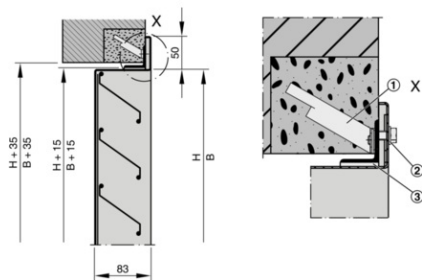

- ① Fixing tab
- ② Hexagon head screw with washer
- ③ Installation subframe

Installation dimensions – WG-AL

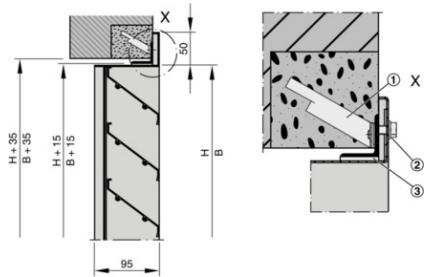

- ① Fixing tab
- ② Hexagon head screw with washer
- ③ Installation subframe

Installation subframe, width subdivided

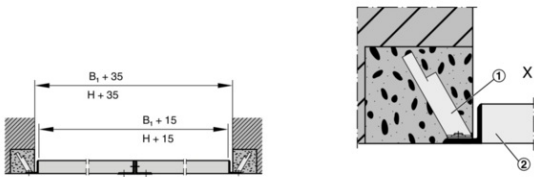

- ① Fixing tab
- ② Installation subframe

Installation subframe, height subdivided

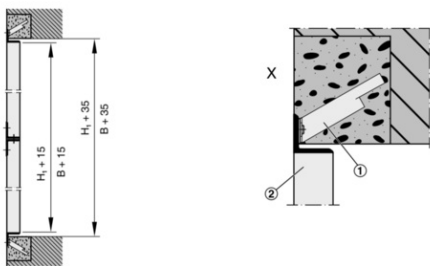

- ① Fixing tab
- ② Installation subframe

Horizontal runs of WG-B-AL

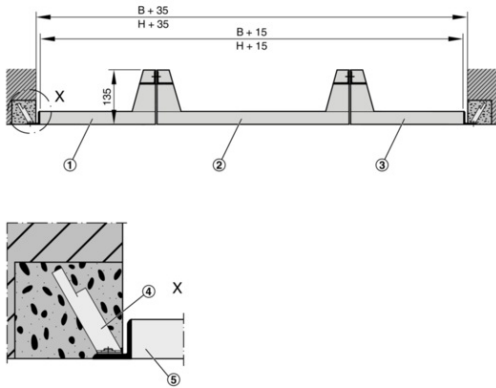

- ① for left end section
- ② for middle section
- ③ for right end section
- ④ Fixing tab
- ⑤ Installation subframe

Installation dimensions - WGK

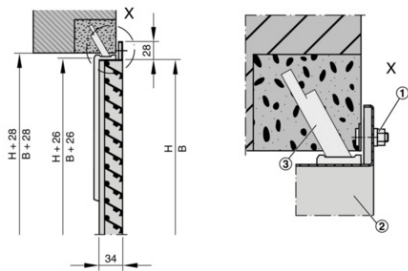

- ① Threaded stud
- ② Installation subframe
- ③ Fixing tab

Installation dimensions - WG-JZ-P, WG-JZ-S, WG-AL-JZ-P, WG-AL-JZ-S

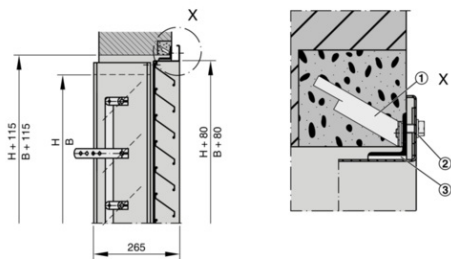

- ① Fixing tab
- ② Hexagon head screw with washer
- ③ Installation subframe

Illustration shows WG-J-P/.../ER

Wall installation without installation subframe

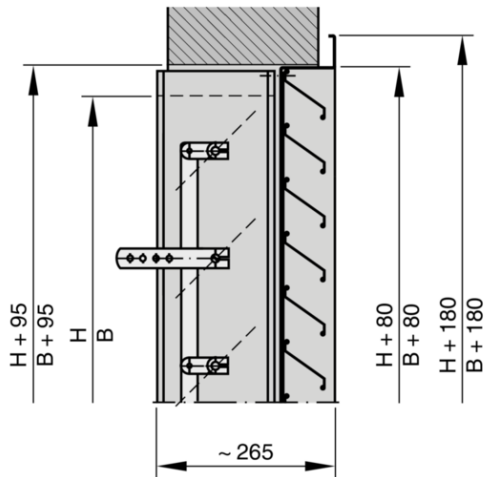
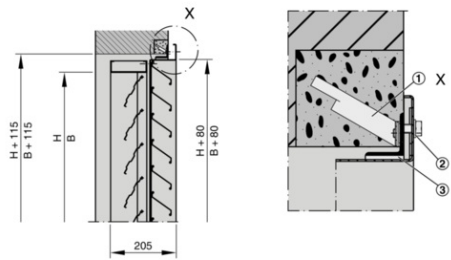

Illustration shows WG-JZ-P, operating side on the right

Installation dimensions - WG-KUL-1, WG-KUL-2, WG-AL-KUL-1, WG-AL-KUL-2



- ① Fixing tab
- ② Hexagon head screw with washer
- ③ Installation subframe

Illustration shows WG-KUL-1/.../ER

Wall installation without installation subframe

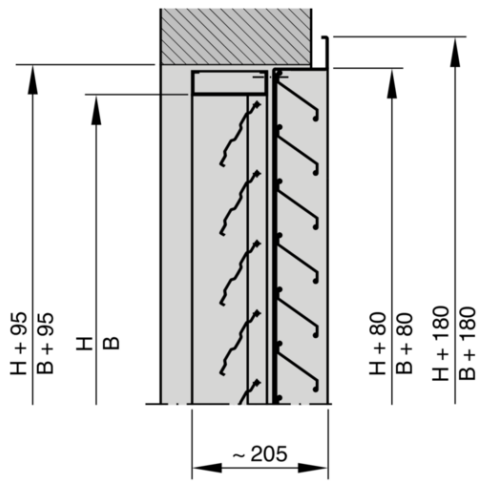

Illustration shows WG-KUL-1