



**LOW-LEAKAGE  
INSPECTION ACCESS  
DOOR, VARIANT BS-R**

Low-leakage inspection  
access door, hinged on the  
left



**INSPECTION WINDOW**



**CYLINDER RIM LOCK**



**REMOVABLE FRONT  
LOCKING LEVER (OF  
DOUBLE LEVER LOCKING  
DEVICE)**



**DOUBLE LEVER LOCKING  
DEVICE (INTERIOR  
LEVER, DOUBLE LEAF  
DOOR)**

## **BS**

### **INSPECTION ACCESS DOORS FOR FILTER CHAMBERS, AIR HANDLING UNITS OR OTHER ENCLOSURES WITH MACHINERY OR EQUIPMENT**

Rectangular single leaf inspection access doors that are robust and

ensure only minimal leakage even in case of large differential pressures

- Minimum width of 300 mm, minimum height of 300 mm
- Maximum width of 800 mm, maximum height of 800 mm
- Maximum pressure loading of 1000 Pa, in closing direction, up to nominal size 600 × 600 mm 2000 Pa
- Air leakage rate of approx. 0.6 l/s or 2 m<sup>3</sup>/h at 1000 Pa, up to nominal size 600 × 600 mm approx. 1.1 l/s or 4 m<sup>3</sup>/h at 2000 Pa
- Double skin door leaf made of galvanised sheet steel and with mineral wool infill
- Door frame made of angle sections
- Double lever locking device, can be operated from both sides
- APT rubber seal, temperature resistant up to 90 °C
- Available in standard sizes and many intermediate sizes

Optional equipment and accessories

- Cylinder rim lock, mortice lock, inspection window and removable exterior locking lever
- Powder-coated for outdoor installation

## Application



### Application

- Low-leakage inspection access doors of Type BS are used as separating elements for air handling units, filter chambers, or enclosures for machinery or electrical equipment
- Robust construction with very low air leakage rate even in case of large differential pressures
- Powder-coated construction with increased corrosion resistance
- Maximum pressure on the opening side is 1000 Pa, up to nominal size 600 × 600 mm 2000 Pa

### Special characteristics

- U-value: 1.02 W/(m<sup>2</sup>K) at 8 W/(m<sup>2</sup>K) for internal spaces (air not in motion) and 25 W/(m<sup>2</sup>K) for outside (air in motion)
- Optional door frame without fixing tabs (-21) but with flange holes

### Nominal sizes

- B: 500, 600 mm (intermediate sizes: 300 – 800 mm, in increments of 1 mm)
- H: 500, 600 mm (intermediate sizes: 300 – 800 mm, in increments of 1 mm)
- Any combination of B × H

## Description



### Variants

- R: Right hinge
- L: Left hinge
- 11: Angle section frame with welded fixing tabs
- 21: Angle section frame without fixing tabs

### Parts and characteristics

- Door with perimeter seal
- Double lever locking device
- Absorption material
- Hinges
- Frame

### Attachments

- Locks, inspection window, front locking lever: for the improvement and extension of the range of applications

### Construction features

- Double skin door leaf; skin thickness of 1 mm and 1.25 mm (opening side), respectively
- Stiffeners at the level of the double lever locking devices
- Double lever locking device, can be operated from both sides
- Seal is temperature resistant up to 90 °C
- Maximum pressure loading of 1000 Pa (in closing direction), up to nominal size 600 × 600 mm 2000 Pa; air leakage rate of approx. 0.6 l/s or 2 m<sup>3</sup>/h at 1000 Pa, up to nominal size 600 × 600 mm approx. 1.1 l/s or 4 m<sup>3</sup>/h at 2000 Pa

### Materials and surfaces

- Door leaf and stiffeners made of galvanised sheet steel
- Absorption material is mineral wool
- Door frame made of galvanised steel 50 × 50 × 4 mm
- Double lever locking device made of aluminium diecast
- APT rubber seal
- P1: Powder-coated, RAL CLASSIC colour
- PS: Powder-coated, NCS or DB colour

### Mineral wool

- To DIN 4102, fire rating class A2, non-combustible
- RAL quality mark RAL-GZ 388
- Biosoluble according to TRGS 905 and EU directive 97/69/EG
- Inert to fungal and bacterial growth

### Maintenance

- Maintenance-free as construction and materials are not subject to wear
- Contamination should be removed as it may lead to corrosion and to increased closed door air leakage

## TECHNICAL INFORMATION

Function, Technical data, Specification text, Order code, Related products

---



**Functional description**

Low-leakage inspection access doors are low-leakage separating elements for rooms or other enclosures.

When the door is being closed, i.e. when the double locking levers are being turned, the perimeter seal is fully pressed against the frame. As a consequence, the air leakage rate is extremely low even in case of high differential pressures.

**Schematic illustration of BS**

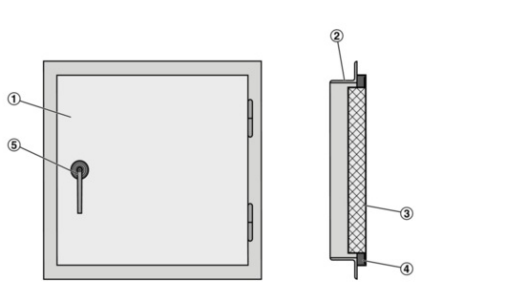

- ① Door
- ② Frame (angle section 50 × 50 × 4 mm)
- ③ Absorption material
- ④ Seal
- ⑤ Double lever locking device

<b>Nominal sizes</b>	300 × 300 – 800 × 800 mm
<b>Maximum pressure on the opening side</b>	1000 Pa, up to nominal size 600 × 600 mm 2000 Pa
<b>Weighted sound reduction index</b>	43 – 46 dB

**Weighted sound reduction index**

Centre frequency $f_m$ [Hz]				
125	250	500	1000	2000
$R_w$				
dB				
26	38	44	46	46

Low-leakage inspection access doors as separating elements for air handling units, filter chambers, or enclosures for machinery or electrical equipment.

Ready-to-install component that consists of a door leaf with double lever locking device, absorption material, seal and hinges, and a frame.

Air leakage rate on the opening side is approx. 0.6 l/s or 2 m<sup>3</sup>/h at 2000 Pa.

#### **Special characteristics**

- U-value: 1.02 W/(m<sup>2</sup>K) at 8 W/(m<sup>2</sup>K) for internal spaces (air not in motion) and 25 W/(m<sup>2</sup>K) for outside (air in motion)
- Optional door frame without fixing tabs (-21) but with flange holes

#### **Materials and surfaces**

- Door leaf and stiffeners made of galvanised sheet steel
- Absorption material is mineral wool
- Door frame made of galvanised steel 50 × 50 × 4 mm
- Double lever locking device made of aluminium diecast
- APT rubber seal
- P1: Powder-coated, RAL CLASSIC colour
- PS: Powder-coated, NCS or DB colour

#### **Mineral wool**

- To DIN 4102, fire rating class A2, non-combustible
- RAL quality mark RAL-GZ 388
- Biosoluble according to TRGS 905 and EU directive 97/69/EG
- Inert to fungal and bacterial growth

#### **Technical data**

- Nominal sizes: 300 × 300 - 800 × 800 mm
- Maximum pressure on the opening side is 1000 Pa, up to nominal size 600 × 600 mm 2000 Pa
- Weighted sound reduction index: 43 - 46 dB

This specification text describes the general properties of the product. Texts for variants can be generated with our Easy Product Finder design programme.

**Order example: BS-L/500×650/Z03**

Variant	Left hinge
Nominal size	500 × 650 mm
Attachments	With inspection window
Surface	Standard construction

**BS – R / 500×500 / Z03 / P1 – RAL ...**



**1 Type**

**BS** Low-leakage inspection access door

**2 Construction**

**R** Right side  
**L** Left side

**3 Nominal size [mm]**

B × H

**4 Attachments**

No entry: none  
**Z01 – Z03**  
**Z05**

**5 Surface**

No entry: standard construction  
**P1** Powder-coated, RAL CLASSIC colour  
**PS** Powder-coated, DB colour

Gloss level  
RAL 9010 50 %  
RAL 9006 30 %  
All other RAL colours 70 %

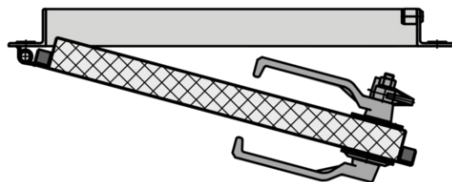
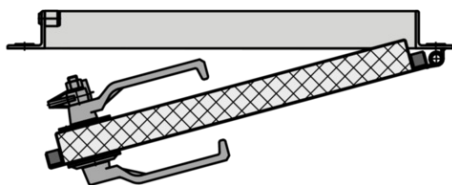

**BS, weights**

H	B [mm]			
	400	500	600	800
mm	kg			
400	12	15	18	24
500	13	16	19	25
600	13	17	20	26
800	14	18	21	27

**BS**

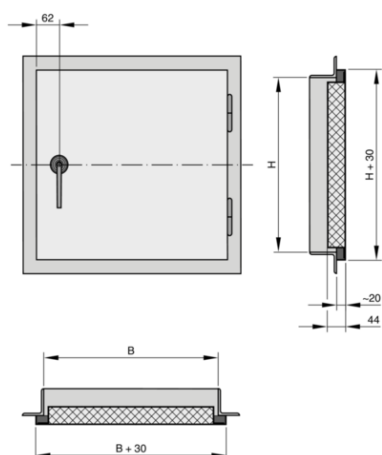
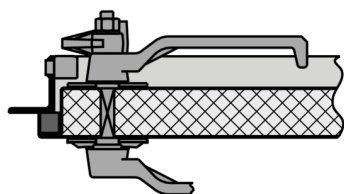

Illustration shows right hinge

Double lever locking device on angle section door frame



**Installation and commissioning**

- Align the frame precisely before mortaring it in
- When the door is closed, the perimeter seal must be in full contact with the frame

**No. of fixing tabs on each side**

Sizes mm	n Qty
300 - 499	1
500 - 800	2

**Wall installation**

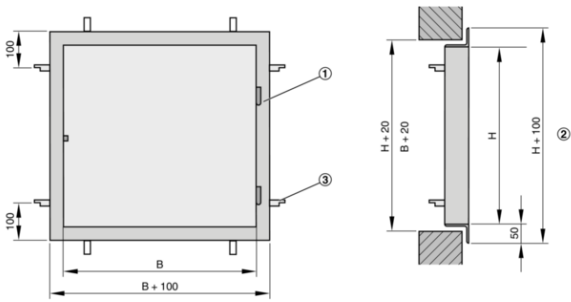

- ① Frame
- ② Opening side
- ③ Fixing tab

Illustration shows right hinge

**Installation into an enclosure**

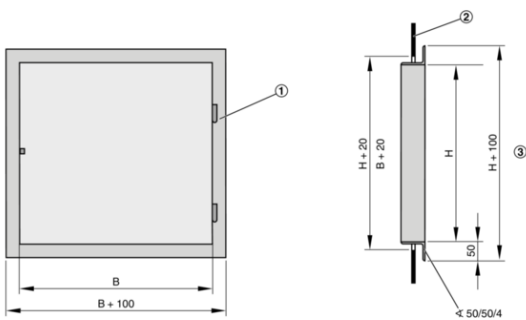

- ① Frame
- ② Enclosure, e. g. filter chamber
- ③ Opening side

Illustration shows right hinge